

Low Capacitance

Stand-Off Voltage: 5.0 to 50 V

Peak Pulse Power: 500 W

**Axial Lead
Transient Voltage Suppressors**

Features

- Glass passivated chip
- 500 W peak pulse power capability with a 10/1000 μ s waveform, repetitive rate (duty cycle):0.01 %
- Low leakage
- Excellent clamping capability
- Very fast response time
- RoHS compliant

Mechanical Data

- Case: molded plastic
- Epoxy: UL 94V-0 rate flame retardant
- Lead: Solderable per MIL-STD-750, method 2026 guaranteed
- Polarity: Color band denotes TVS cathode end
- Mounting position: Any

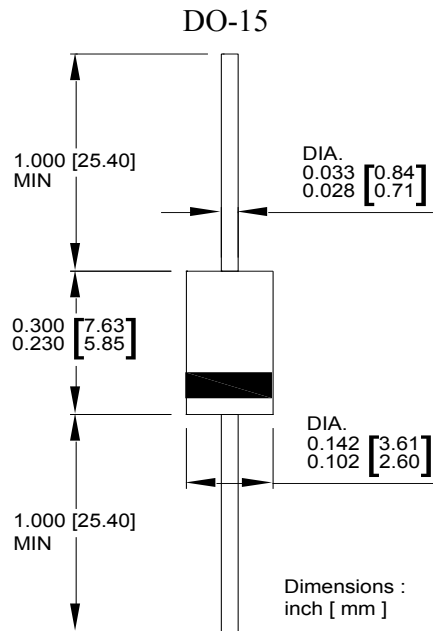

Maximum Ratings($T_A=25^{\circ}C$ unless otherwise noted)

Parameter	Symbol	Value	Unit
Peak power dissipation with a 10/1000 μ s waveform ⁽¹⁾	P_{PP}	500	W
Power dissipation on infinite heatsink at $T_L = 75^{\circ}$ C(Fig.2)	P_D	3.0	W
Peak pulse current with a 10/1000 μ s waveform(Fig.2) ⁽¹⁾	I_{PP}	See Next Table	A
Operating junction and storage temperature range	T_J, T_{STG}	- 55 to +150	$^{\circ}C$

Note:

(1)Non-repetitive current pulse per Fig.3 and derated above $T_A= 25^{\circ}C$ per Fig.2

Ratings and Characteristics Curves ($T_A=25^{\circ}\text{C}$ unless otherwise noted)

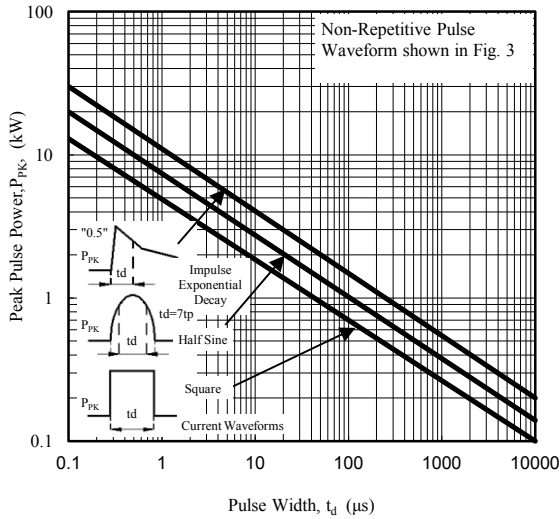

Fig. 1 - Peak Pulse Power Rating Curve

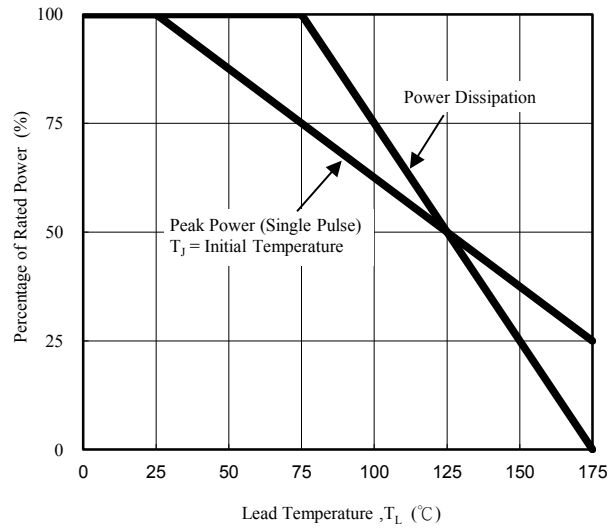

Fig. 2 - Power Derating Curve Surge Current

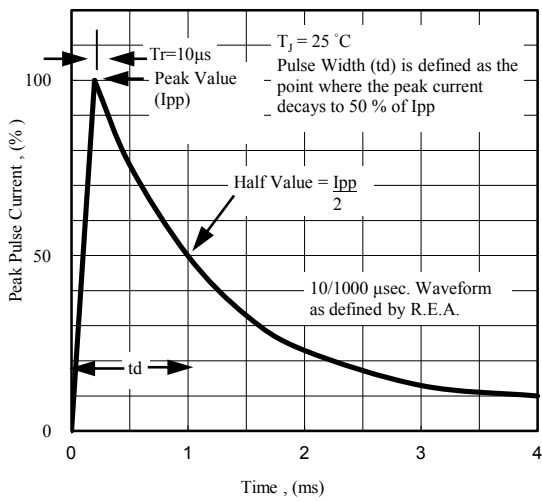
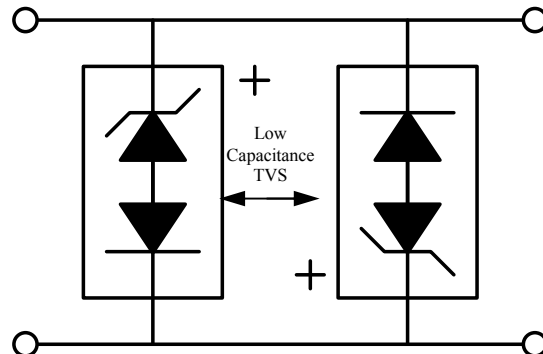

Fig. 3 - Pulse Waveform



Application Note: Device must be used with two units in parallel, opposite in polarity as shown in circuit for AC signal line protection.

Fig. 4 - AC Line Protection Application

Electrical Characteristics($T_A=25^{\circ}\text{C}$ unless otherwise noted)

Part Number	Stand-Off Voltage V_{WM} (V)	Minimum Breakdown Voltage $V_{BR}@I_T=1.0\text{mA}$ (V)	Maximum Reverse Leakage I_R @ V_{WM} (μA)	Maximum Clamping Voltage V_C @ I_{PP} (V)	Maximum Reverse Surge Current I_{PP} (A)	Maximum Junction Capacitance @0 V (pF)	Working Inverse Blocking Voltage V_{WIB} (V)	Inverse Blocking Leakage Current I_{IB} @ V_{WIB} (mA)	Peak Inverse Voltage V_{PIB} (V)
SAC5.0	5.0	7.60	300	10.0	44.00	50	75	1	100
SAC6.0	6.0	7.90	300	11.2	41.00	50	75	1	100
SAC7.0	7.0	8.33	300	12.6	38.00	50	75	1	100
SAC8.0	8.0	8.89	100	13.4	36.00	50	75	1	100
SAC8.5	8.5	9.44	50	14.0	34.00	50	75	1	100
SAC10	10.0	11.10	5	16.3	29.00	50	75	1	100
SAC12	12.0	13.30	5	19.0	25.00	50	75	1	100
SAC15	15.0	16.70	5	23.6	20.00	50	75	1	100
SAC18	18.0	20.00	5	28.8	15.00	50	75	1	100
SAC22	22.0	24.40	5	35.4	14.00	50	75	1	100
SAC26	26.0	28.90	5	42.3	11.10	50	75	1	100
SAC30	30.0	33.30	5	48.6	10.00	50	75	1	100
SAC36	36.0	40.00	5	60.0	8.60	50	75	1	100
SAC45	45.0	50.00	5	77.0	6.80	50	150	1	200
SAC50	50.0	55.50	5	88.0	5.80	50	150	1	200